

S6

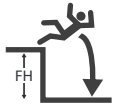

EN1176

1.80m

EN1176

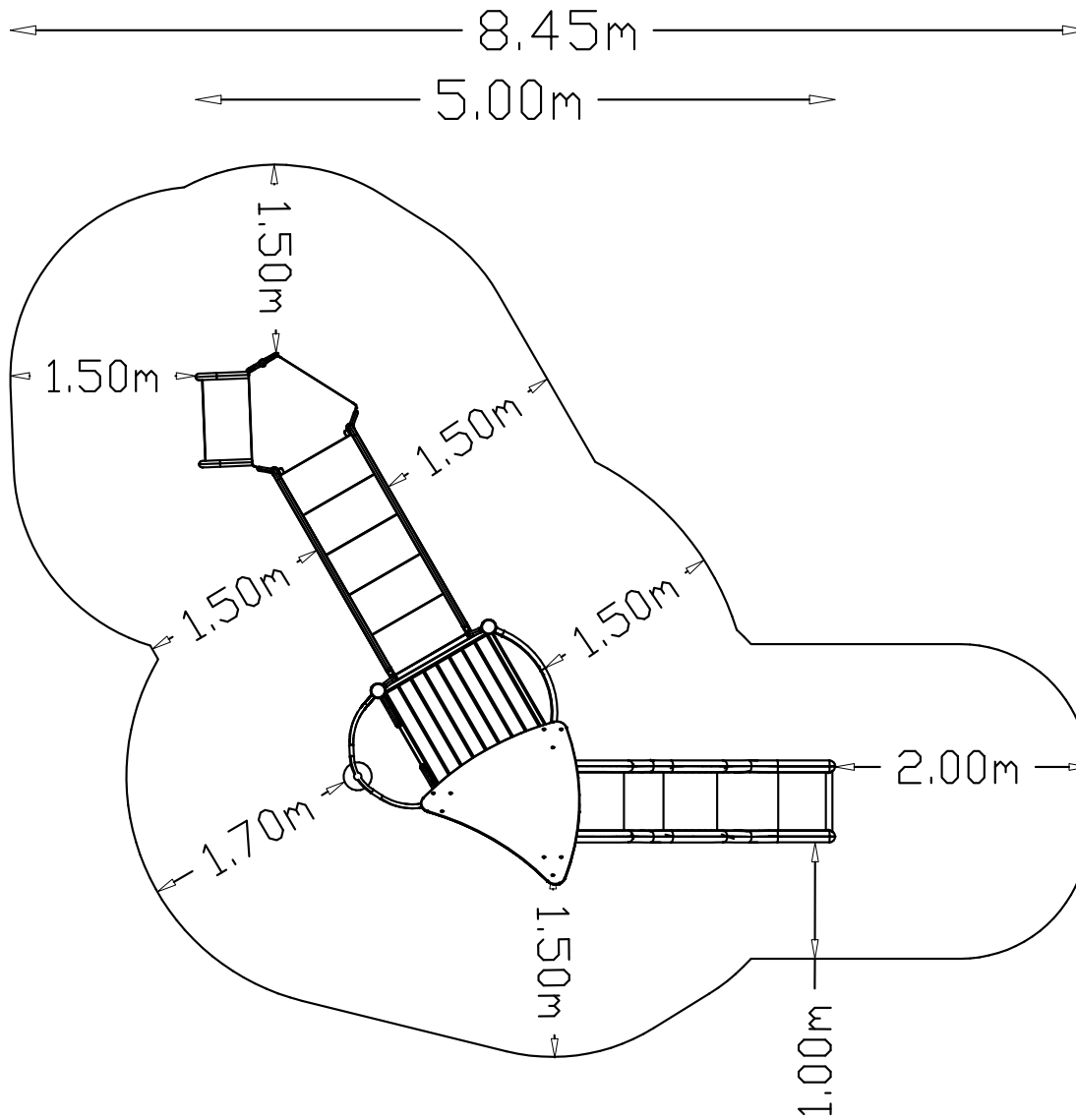

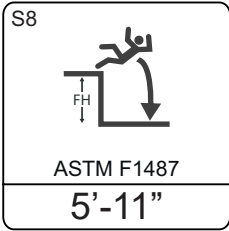

ASTM F1487

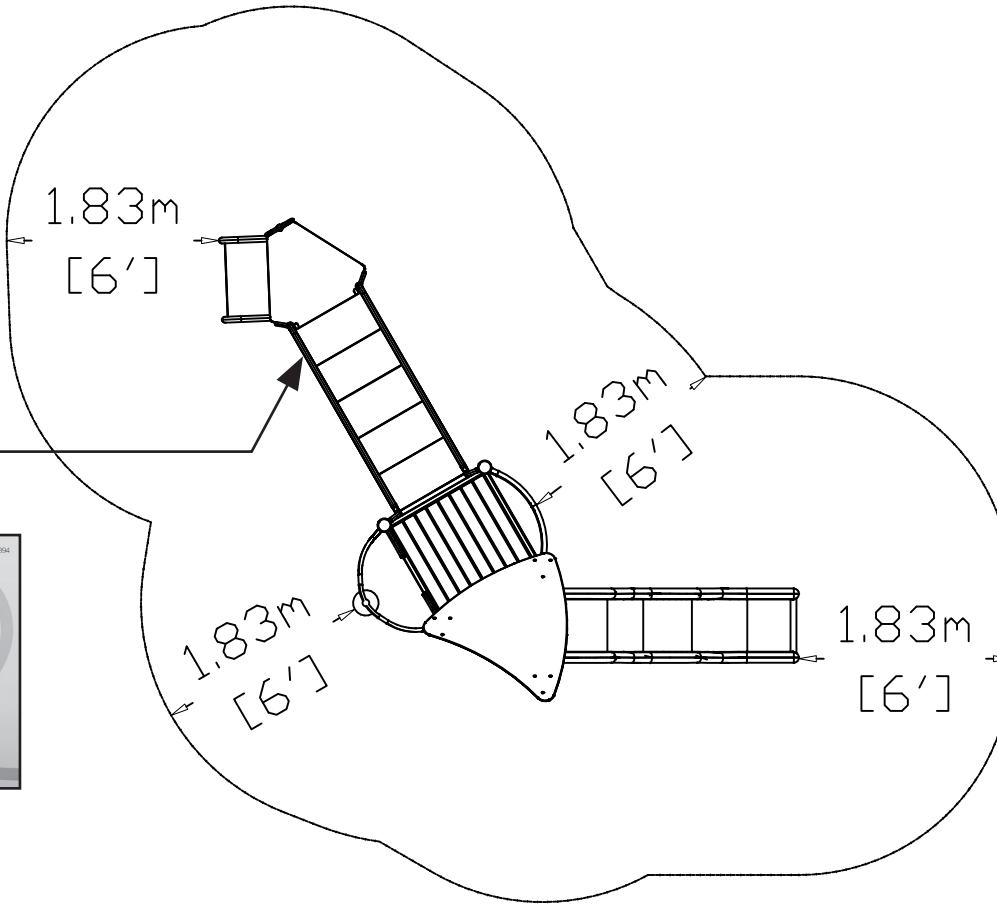
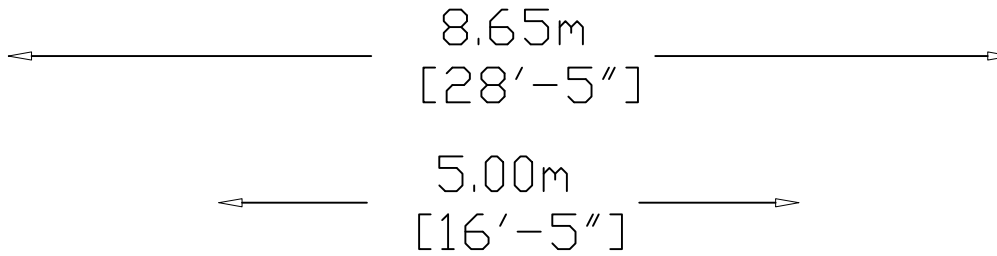

INSTALL 101

<p>WARNING</p> <p>Playground equipment should not be used as a structure, scaffold or ladder. Children should never play or climb on the equipment. Do not use the equipment as a swing set. Do not use the equipment as a slide.</p>	<p>play smart! rules</p> <ul style="list-style-type: none"> Do not play on broken or damaged equipment. Report it. Do not play without adequate safety clothing and personal equipment. No talking, running or shouting should be done while on equipment. Do not play tag or run on playground equipment and its structure off of equipment. Watch your head! Do not run, climb, swing, slide, rotate, or spin. Do not play on swings or on playground equipment when equipment is wet. Do not play on swings or on equipment if the seat or on top of seat through hole or slot. Do not slide on metal, concrete, or asphalt. Do not slide up stairs or ladders. Adults - do not slide with a child on your lap. It can injure your child's legs. Before letting go of overhead bars, hand down with hand your hands a little and then straight down with both feet. Always swing down with the feet and always swing down with the feet.
<p>WARNING</p> <p>Children are required to use only one surface caught on slides and other playground equipment. Before allowing children to play, remove foreign objects, debris, and debris accumulated through the slides. Also, remove any foreign objects, debris, or other items that may be on or in equipment.</p>	<p>WARNING</p> <p>All playground equipment and rubber surfacing must be inspected for proper footing. Check for hot surfaces before allowing children to play. Children should wear appropriate shoes at all times.</p>
<p>WARNING</p> <p>Playground equipment on an uneven playground surface can lead to serious injury from falls, collisions, and head strikes. Do not use equipment on uneven playground surfaces. The situation while playing will be equalized.</p>	<p>WARNING</p> <p>Do not play on equipment if the seat or on top of seat through hole or slot. Do not slide on metal, concrete, or asphalt. Do not slide up stairs or ladders. Adults - do not slide with a child on your lap. It can injure your child's legs. Before letting go of overhead bars, hand down with hand your hands a little and then straight down with both feet. Always swing down with the feet and always swing down with the feet. </p>



S9

CSA Z 614
2.45m
[8'-1/2"]

CSA Z614

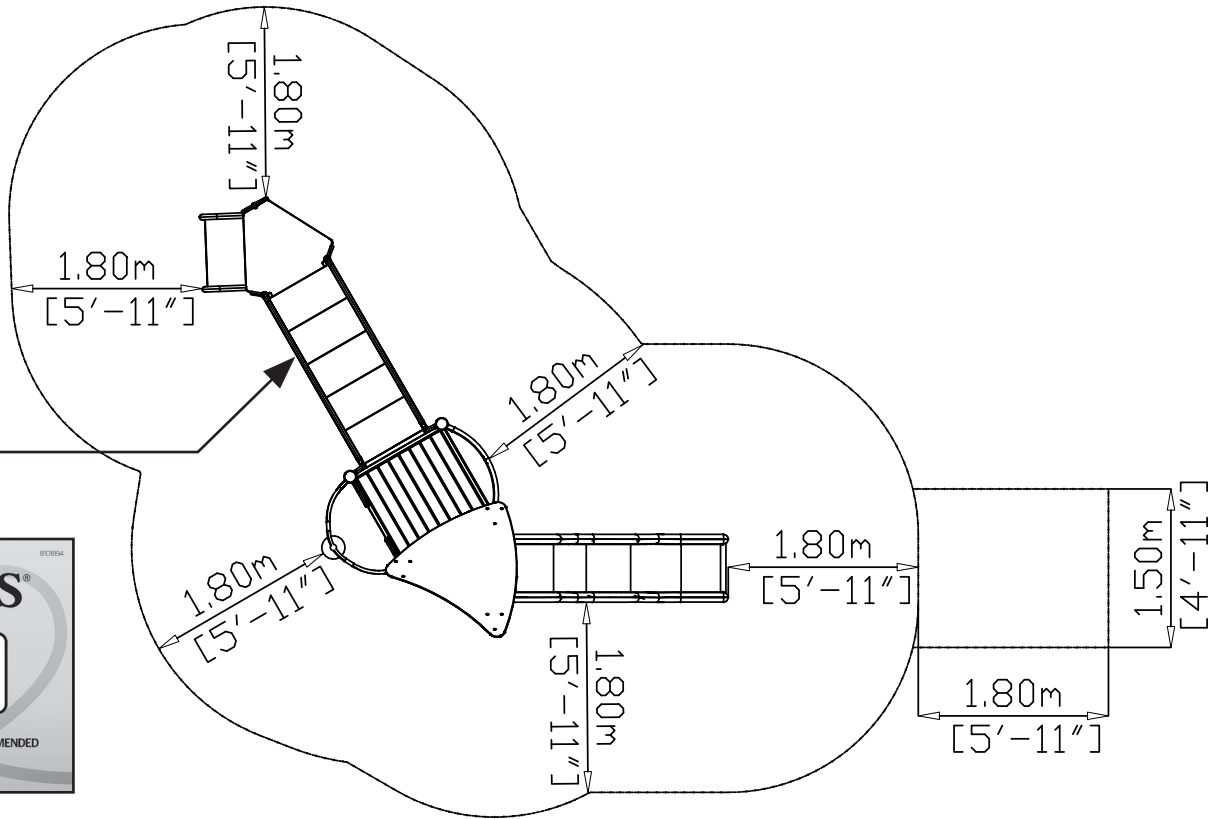
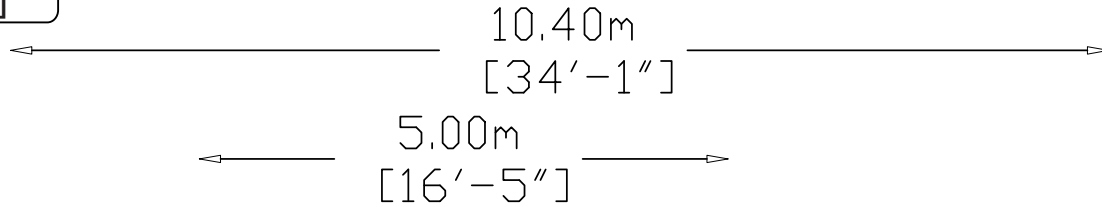

INSTALL 101

<p>WARNING</p> <p>Playground equipment must not be used as a structure, scaffold or platform. Adults must supervise play at all times. Do not use the playground while drinking or eating. Do not use the playground while wearing jewelry or loose clothing.</p>	<p>WARNING</p> <p>Children are required to use stairs and ladders caught on slides and other playground equipment. Before playing children to play before falling, always, hold onto handrails, and release themselves through the slides. Also, never use longer runs, steps, or other handrails.</p>	<p>play smart® rules</p> <ul style="list-style-type: none"> Do not play on broken or damaged equipment. Do not play without adequate safety clothing and footwear. No talking, running or shouting should be done while playing. Do not play tag or run on playground equipment and do not play on equipment. Watch your head! Do not run, climb, swing, slide, or jump. Do not play on swings or any equipment. Do not climb on walls, fences, or posts. Do not play on trees or through trees. Do not drink or eat while playing. Do not climb on walls, fences, or posts. Do not climb on trees or through trees. Do not drink or eat while playing. Do not climb on walls, fences, or posts. Do not climb on trees or through trees. Do not drink or eat while playing.
<p>WARNING</p> <p>All playground equipment and rubber surfacing must be inspected for proper fitting. Check for hot surfaces before allowing children to play. Children should wear appropriate shoes at all times.</p>	<p>WARNING</p> <p>Playing tag or running on or under playground equipment can lead to serious injury from falls, collisions, and head strikes. Do not use the playground equipment. Play equipment while playing and be careful.</p>	<p>WARNING</p> <ul style="list-style-type: none"> Adults - do not slide with a child on your lap. It can injure your child's legs. Before letting go of overhead bars, hand down with both hands a slide and slide straight down with both feet. Before sliding down, do not pull or push on the slide. Do not swing while playing and be careful.

HAGS®

FOR KIDS AGES
5-12
YEARS

ADULT SUPERVISION RECOMMENDED
www.hags.com

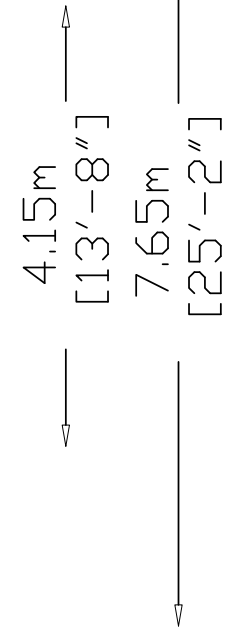

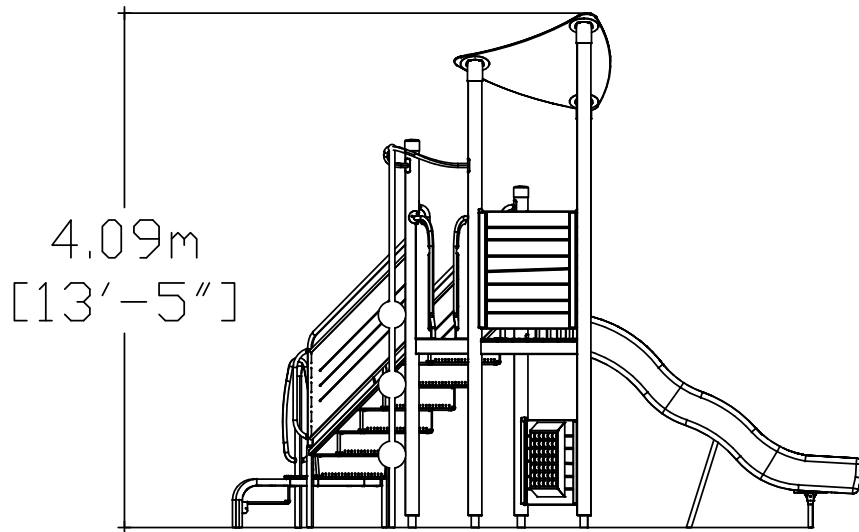
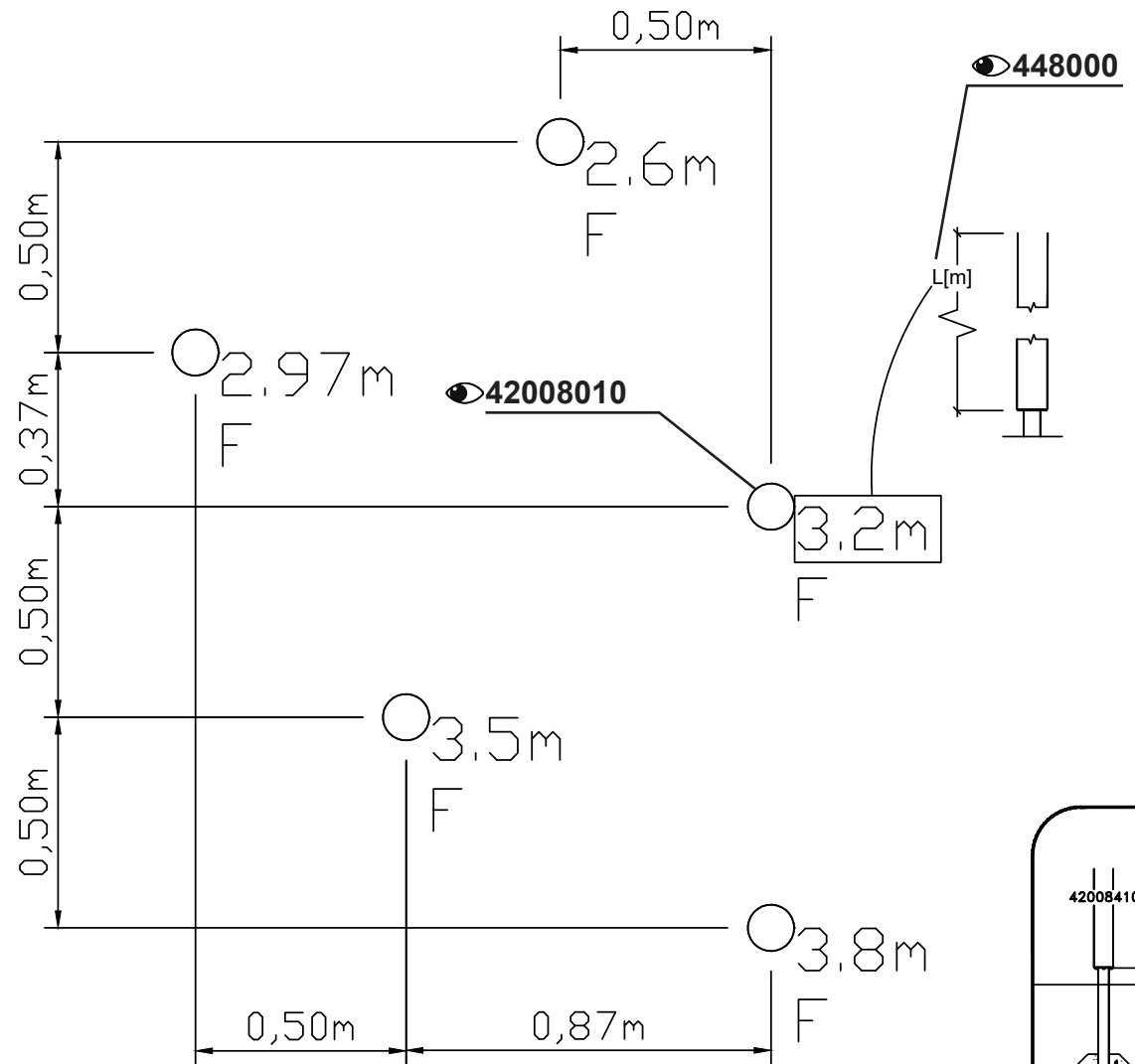
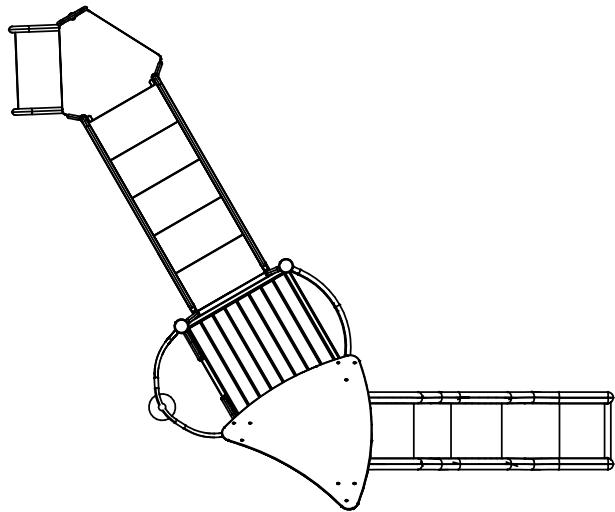

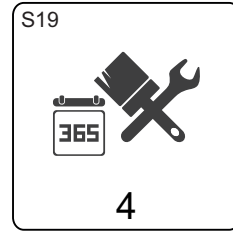
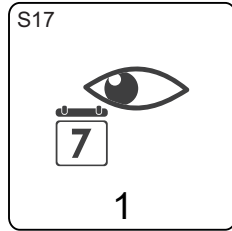
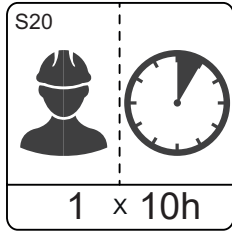
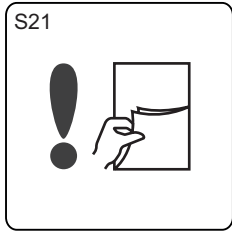

Install 101

260329

420960

426162

426200

448000

42008010

42275323

42475323

MA422U77151

MA424U77151

MA426121

MASW103874

MASW34156

MASW38904

MASW39775

MASW85869

 **42008010**

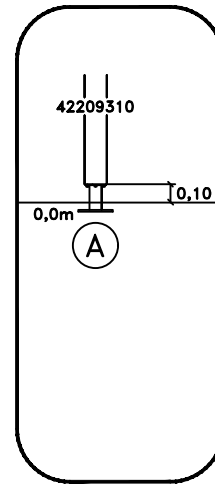

Above Ground

OM

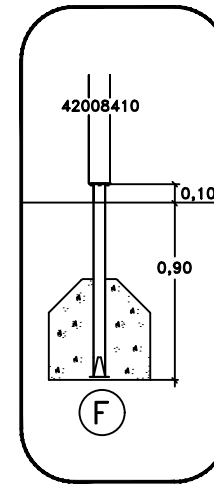

Cast Loose Fill

BM

8102008

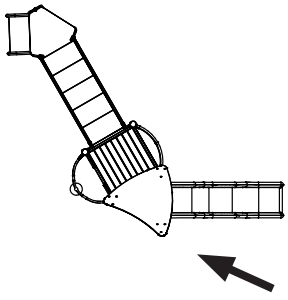

MA426121

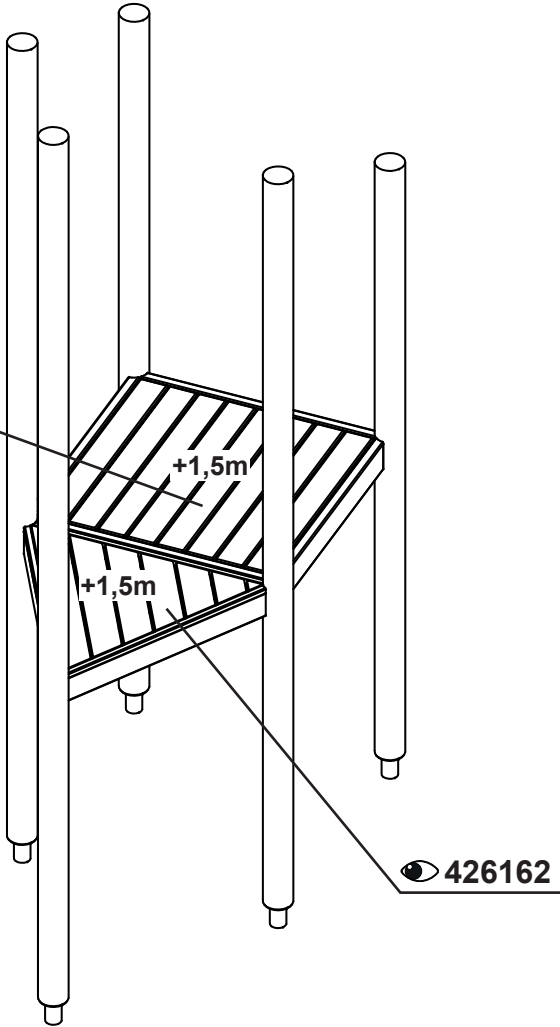

+1,5m

+1,5m

426162

426200
8047223

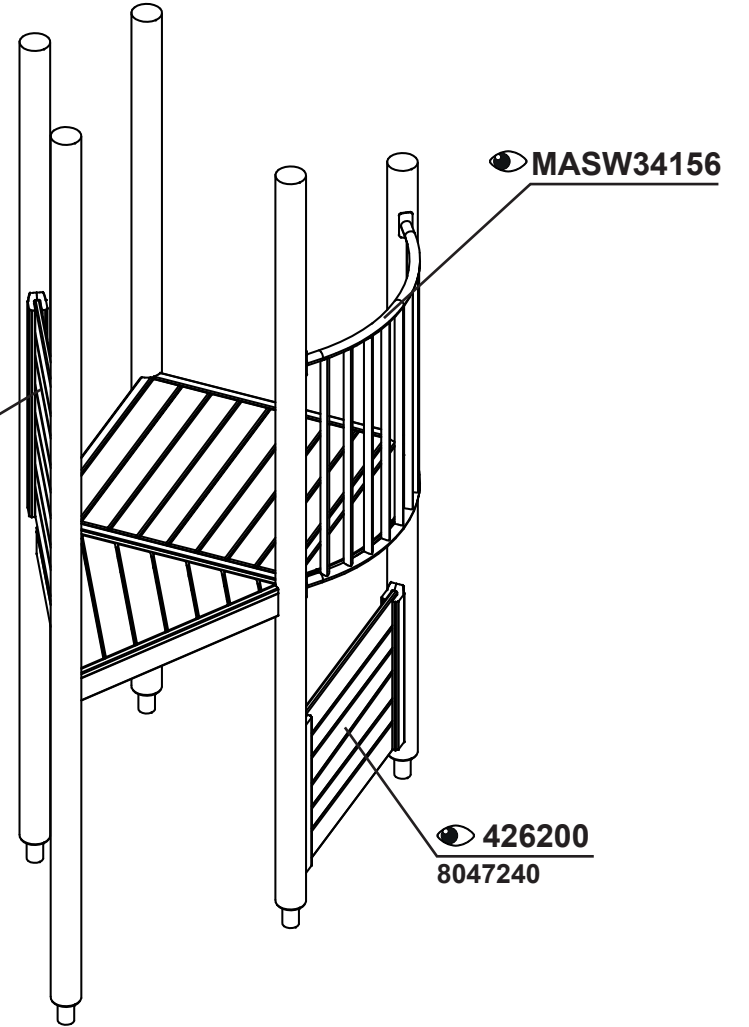

MASW34156

426200
8047240

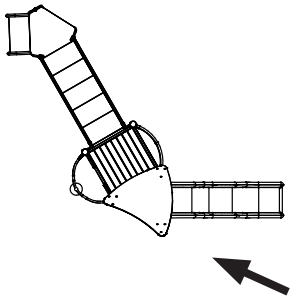

42475323 [BM]

42275323 [OM]

MA424U77151 [BM]

MA422U77151 [OM]

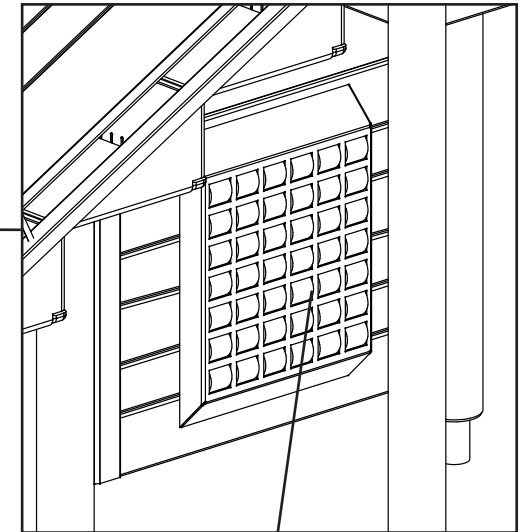
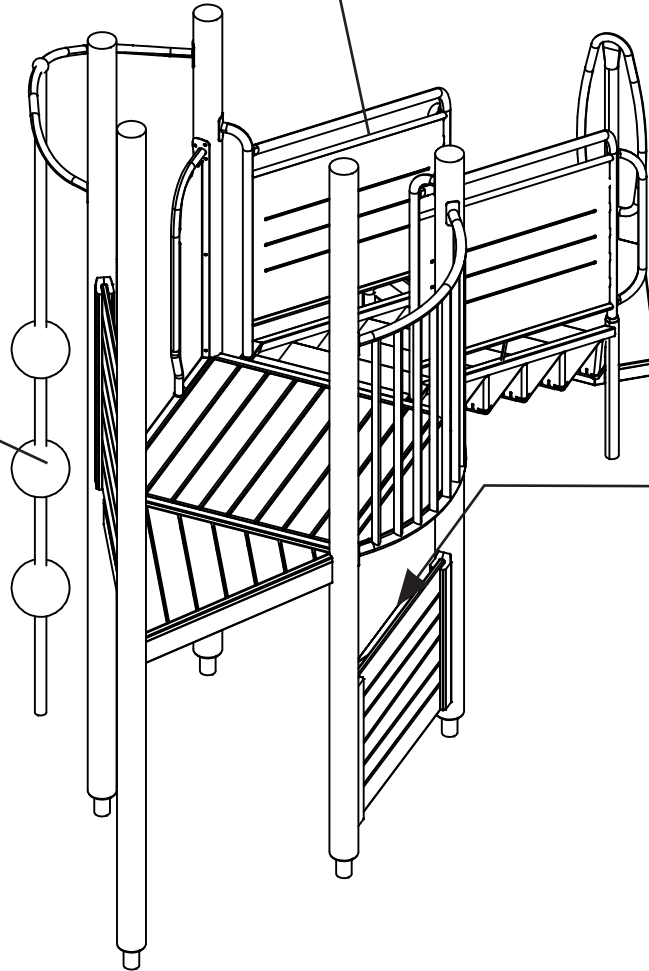

420960

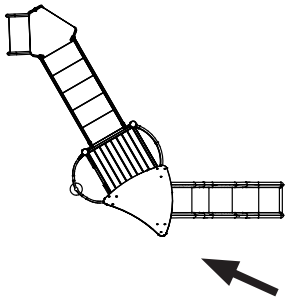

MASW38904

MASW39775

x 2

HAGS
260329

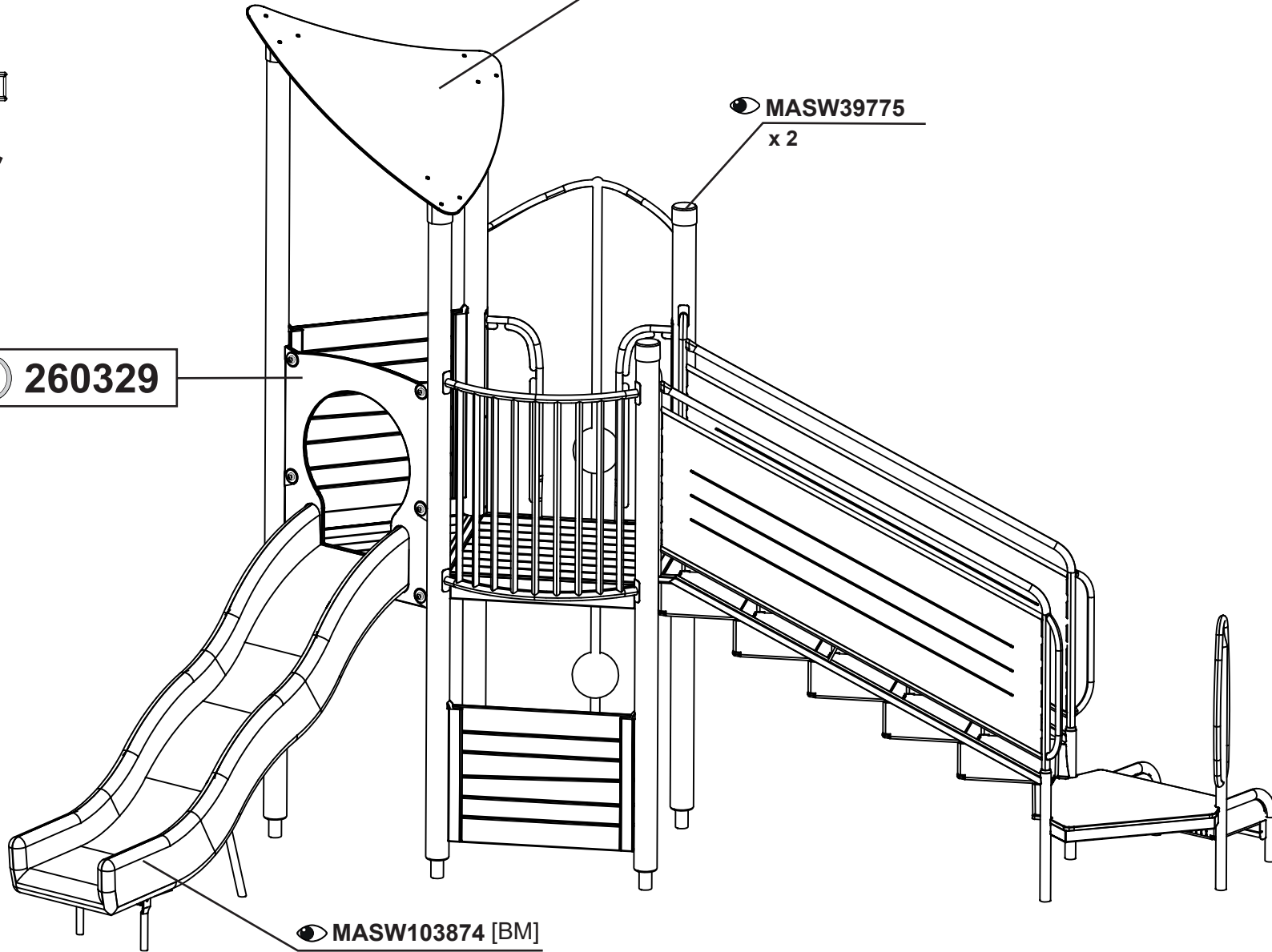

MASW103874 [BM]

MASW85869 [OM]